

Snijringen en moeren: (M..L en M Z).

Buis diam.	Artikelnr.	..L	Artikelnr.	..Z	Artikelnr.
∅ 6 mm.	S6	L = Lichte uitvoering.	M 6L	Z = Zware uitvoering.	M6Z
∅ 8 mm.	S8		M 8L		M8Z
∅ 10 mm.	S10		M10L		M10Z
∅ 12 mm.	S12		M12L		M12Z
∅ 14 mm.	S14				M14Z
∅ 15 mm.	S15		M15L		
∅ 16 mm.	S16				M16Z
∅ 18 mm.	S18		M18L		
∅ 20 mm.	S20				M20Z
∅ 22 mm.	S22		M22L		
∅ 25 mm.	S25				M25Z
∅ 28 mm.	S28		M28L		
∅ 30 mm.	S30				M30Z
∅ 35 mm.	S35		M35L		
∅ 38 mm.	S38				M38Z
∅ 42 mm.	S42	M42L			

iHydraulicS

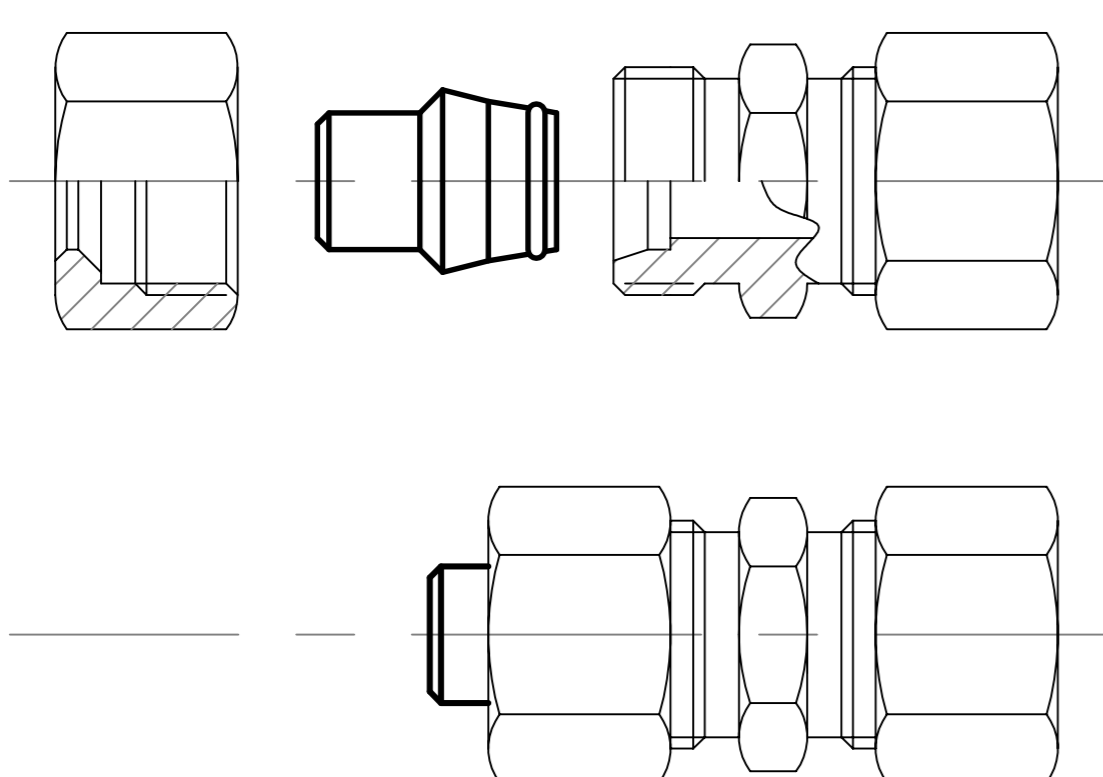

Snijpluggen: (SP..L en SP Z).

Buis diam.	..L	Artikelnr.	..Z	Artikelnr.
∅ 6 mm.	L = Lichte uitvoering.	SP 6L	Z = Zware uitvoering.	
∅ 8 mm.		SP 8L		
∅ 10 mm.		SP10L		
∅ 12 mm.		SP12L		
∅ 14 mm.				SP14Z
∅ 15 mm.		SP15L		
∅ 16 mm.				SP16Z
∅ 18 mm.		SP18L		
∅ 20 mm.				SP20Z
∅ 22 mm.		SP22L		
∅ 25 mm.				SP25Z
∅ 28 mm.		SP28L		
∅ 30 mm.				SP30Z
∅ 35 mm.		SP35L		
∅ 38 mm.				SP38Z
∅ 42 mm.	SP42L			