

#### **Rechte schotverbinding: (VRS..L).**

<b>..L</b>	Werkdruk	Buis diam.	Artikelnr.
<b>L</b> = Lichte uitvoering.	315 Bar	Ø 6 mm.	VRS 6L
	315 Bar	Ø 8 mm.	VRS 8L
	315 Bar	Ø 10 mm.	VRS10L
	315 Bar	Ø 12 mm.	VRS12L
	315 Bar	Ø 15 mm.	VRS15L
	315 Bar	Ø 18 mm.	VRS18L
	160 Bar	Ø 22 mm.	VRS22L
	160 Bar	Ø 28 mm.	VRS28L
	160 Bar	Ø 35 mm.	VRS35L
	160 Bar	Ø 42 mm.	VRS42L

#### **Rechte schotverbinding: (VRS..Z).**

<b>..Z</b>	Werkdruk	Buis diam.	Artikelnr.
<b>Z</b> = Zware uitvoering.	640 Bar	Ø 6 mm.	VRS 6Z
	640 Bar	Ø 8 mm.	VRS 8Z
	640 Bar	Ø 10 mm.	VRS10Z
	640 Bar	Ø 12 mm.	VRS12Z
	640 Bar	Ø 14 mm.	VRS14Z
	400 Bar	Ø 16 mm.	VRS16Z
	400 Bar	Ø 20 mm.	VRS20Z
	400 Bar	Ø 25 mm.	VRS25Z
	400 Bar	Ø 30 mm.	VRS30Z
	315 Bar	Ø 38 mm.	VRS38Z

iHydraulicS

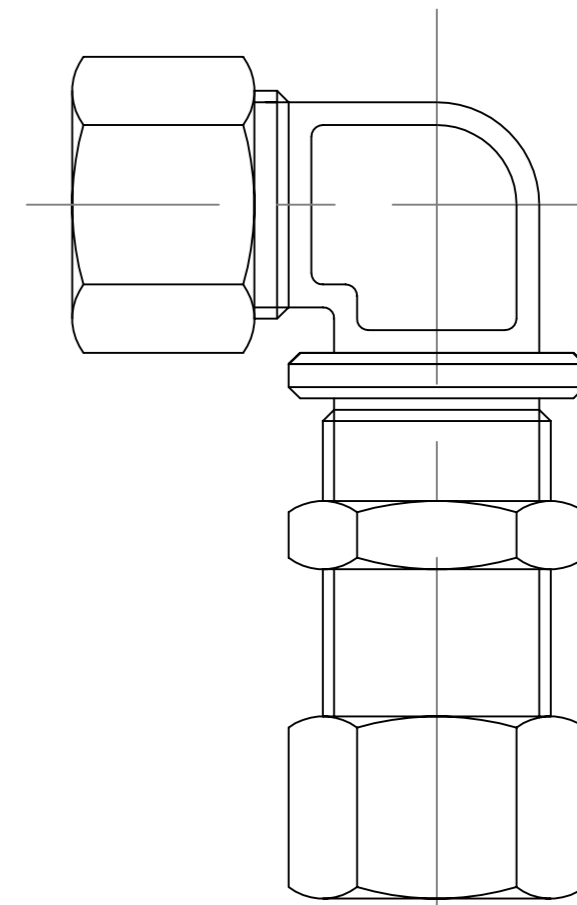
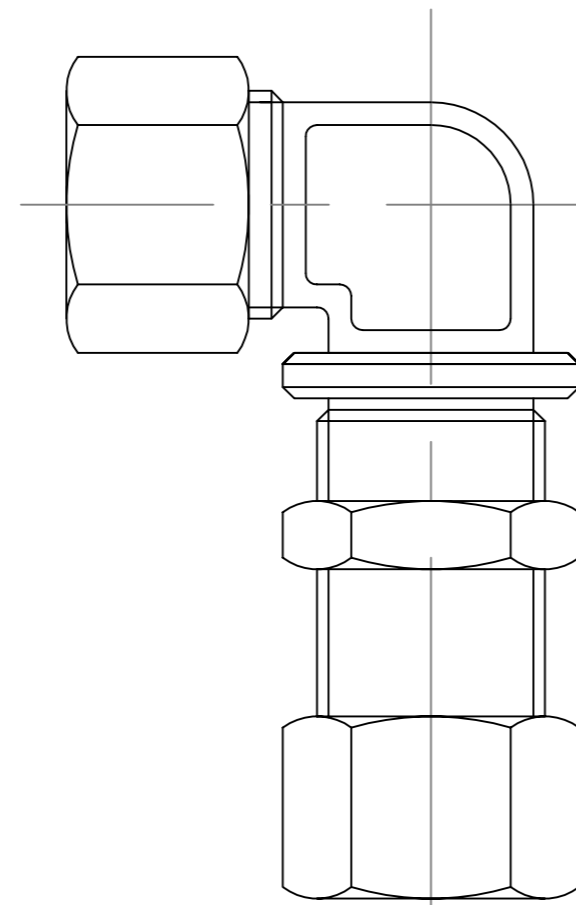

#### **Haakse schotverbinding: (VHS..L).**

<b>..L</b>	Werkdruk	Buis diam.	Artikelnr.
<b>L</b> = Lichte uitvoering.	315 Bar	Ø 6 mm.	VHS 6L
	315 Bar	Ø 8 mm.	VHS 8L
	315 Bar	Ø 10 mm.	VHS10L
	315 Bar	Ø 12 mm.	VHS12L
	315 Bar	Ø 15 mm.	VHS15L
	315 Bar	Ø 18 mm.	VHS18L
	160 Bar	Ø 22 mm.	VHS22L
	160 Bar	Ø 28 mm.	VHS28L
	160 Bar	Ø 35 mm.	VHS35L
	160 Bar	Ø 42 mm.	VHS42L

#### **Haakse schotverbinding: (VHS..Z).**

<b>..Z</b>	Werkdruk	Buis diam.	Artikelnr.
<b>Z</b> = Zware uitvoering.	640 Bar	Ø 6 mm.	VHS 6Z
	640 Bar	Ø 8 mm.	VHS 8Z
	640 Bar	Ø 10 mm.	VHS10Z
	640 Bar	Ø 12 mm.	VHS12Z
	640 Bar	Ø 14 mm.	VHS14Z
	400 Bar	Ø 16 mm.	VHS16Z
	400 Bar	Ø 20 mm.	VHS20Z
	400 Bar	Ø 25 mm.	VHS25Z
	400 Bar	Ø 30 mm.	VHS30Z
	315 Bar	Ø 38 mm.	VHS38Z