

T-verbinding: (VT..L).

..L	Werkdruk	Buis diam.	Artikelnr.
L = Lichte uitvoering.	315 Bar	Ø 6 mm.	VT 6L
	315 Bar	Ø 8 mm.	VT 8L
	315 Bar	Ø 10 mm.	VT10L
	315 Bar	Ø 12 mm.	VT12L
	315 Bar	Ø 15 mm.	VT15L
	315 Bar	Ø 18 mm.	VT18L
	160 Bar	Ø 22 mm.	VT22L
	160 Bar	Ø 28 mm.	VT28L
	160 Bar	Ø 35 mm.	VT35L
	160 Bar	Ø 42 mm.	VT42L

T-verbinding: (VT..Z).

..Z	Werkdruk	Buis diam.	Artikelnr.
Z = Zware uitvoering.	640 Bar	Ø 6 mm.	VT 6Z
	640 Bar	Ø 8 mm.	VT 8Z
	640 Bar	Ø 10 mm.	VT10Z
	640 Bar	Ø 12 mm.	VT12Z
	640 Bar	Ø 14 mm.	VT14Z
	400 Bar	Ø 16 mm.	VT16Z
	400 Bar	Ø 20 mm.	VT20Z
	400 Bar	Ø 25 mm.	VT25Z
	400 Bar	Ø 30 mm.	VT30Z
	315 Bar	Ø 38 mm.	VT38Z

iHydraulicS

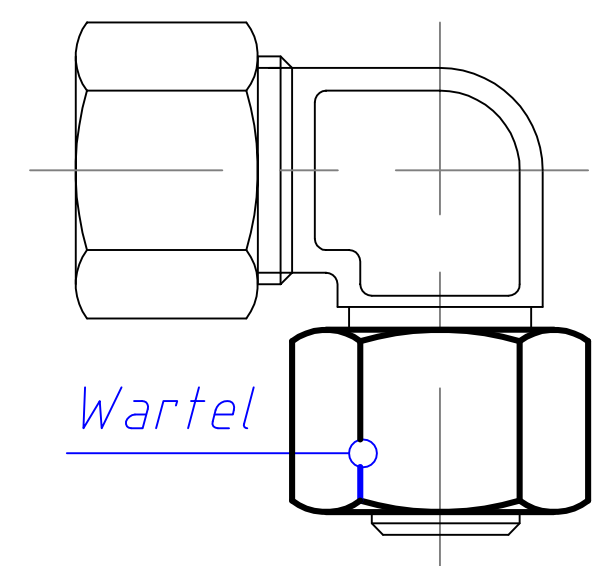
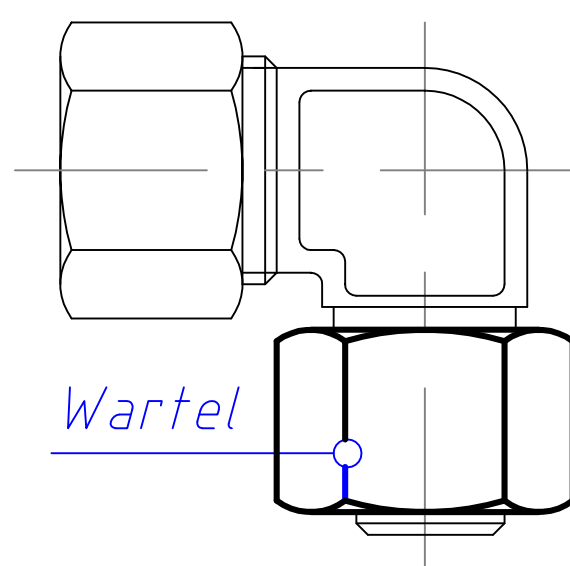

Haakse pijpverbinding: (VHP..L).

..L	Werkdruk	Buis diam.	Artikelnr.
L = Lichte uitvoering.	315 Bar	Ø 6 mm.	VHP 6L
	315 Bar	Ø 8 mm.	VHP 8L
	315 Bar	Ø 10 mm.	VHP10L
	315 Bar	Ø 12 mm.	VHP12L
	315 Bar	Ø 15 mm.	VHP15L
	315 Bar	Ø 18 mm.	VHP18L
	160 Bar	Ø 22 mm.	VHP22L
	160 Bar	Ø 28 mm.	VHP28L
	160 Bar	Ø 35 mm.	VHP35L
	160 Bar	Ø 42 mm.	VHP42L

Haakse pijpverbinding: (VHP..Z).

..Z	Werkdruk	Buis diam.	Artikelnr.
Z = Zware uitvoering.	640 Bar	Ø 6 mm.	VHP 6Z
	640 Bar	Ø 8 mm.	VHP 8Z
	640 Bar	Ø 10 mm.	VHP10Z
	640 Bar	Ø 12 mm.	VHP12Z
	640 Bar	Ø 14 mm.	VHP14Z
	400 Bar	Ø 16 mm.	VHP16Z
	400 Bar	Ø 20 mm.	VHP20Z
	400 Bar	Ø 25 mm.	VHP25Z
	400 Bar	Ø 30 mm.	VHP30Z
	315 Bar	Ø 38 mm.	VHP38Z