

**P820 CON SERBATOIO DA LT 6 - 10 / P820 WITH 6 - 10 L TANK**

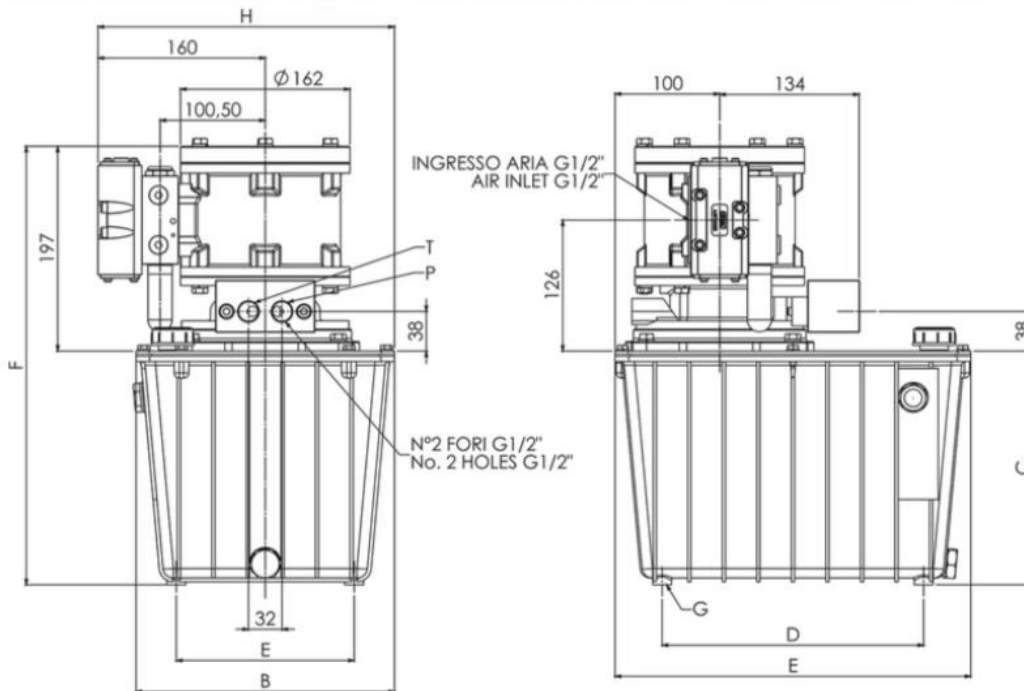

Serbatoio Tank	A	B	C	D	E	F	G	H
Lt	mm	mm	mm	mm	mm	mm	mm	mm
6	280	200	183	210	130	380	M 8	259
10	340	247	225	250	170	422	M 8	284

**DATI TECNICI / TECHNICAL DATA**

Modello Model	P820-5	P820-10	P820-20	P820-30	P820-40	
Rapporto di moltiplicazione Pressure ratio	1 : 5	1 : 10	1 : 20	1 : 30	1 : 40	
Pressione nominale massima Maximum nominal pressure	bar	40	80	160	240	320
Pressione dell'aria Air pressure	bar	1 ÷ 8				
Consumo aria Air consumption	NI/min	750				
Rumorosità Noise level	dB	Rumorosità misurata ad 1 metro / Noise measured at 1 meter 78 ÷ 80				
Peso pompa con serbatoio Pump weight with tank	Kg	2 Lt = 20 Kg 6 Lt = 20 Kg / 10 Lt = 22 Kg	2 Lt = 15 Kg 6 Lt = 15 Kg / 10 Lt = 17 Kg			

**CAPACITÀ SERBATOI ROTONDI  
ROUND TANK CAPABILITY**

**-R** Serbatoio rotondo 2 Lt  
2 L round tank

**CAPACITÀ SERBATOIO ORIZZONTALE  
HORIZONTAL MOUNTING TANK CAPABILITY**

P820-5	P820-10	P820-20	P820-30	P820-40
Lt 1,2	Lt 1,2	Lt 2,6	Lt 2,6	Lt 2,6

**CAPACITÀ SERBATOIO VERTICALE  
VERTICAL MOUNTING TANK CAPABILITY**

P820-5	P820-10	P820-20	P820-30	P820-40
Lt 1,8	Lt 1,8	Lt 2,0	Lt 2,0	Lt 2,0

**CAPACITÀ SERBATOI ROTONDI  
ROUND TANK CAPABILITY**

**-R5** Serbatoio rotondo 5 Lt  
5 L round tank

**CAPACITÀ SERBATOIO ORIZZONTALE  
HORIZONTAL MOUNTING TANK CAPABILITY**

P820-5	P820-10	P820-20	P820-30	P820-40
Lt 4,0	Lt 4,0	Lt 4,5	Lt 4,5	Lt 4,5

**CAPACITÀ SERBATOIO VERTICALE  
VERTICAL MOUNTING TANK CAPABILITY**

P820-5	P820-10	P820-20	P820-30	P820-40
Lt 4,7	Lt 4,7	Lt 5,0	Lt 5,0	Lt 5,0